



No. 649,904.

Patented May 22, 1900.

J. P. BROPHY.  
AUTOMATIC LATHE ATTACHMENT.

(Application filed July 17, 1899.)

(No Model.)

3 Sheets—Sheet 2.

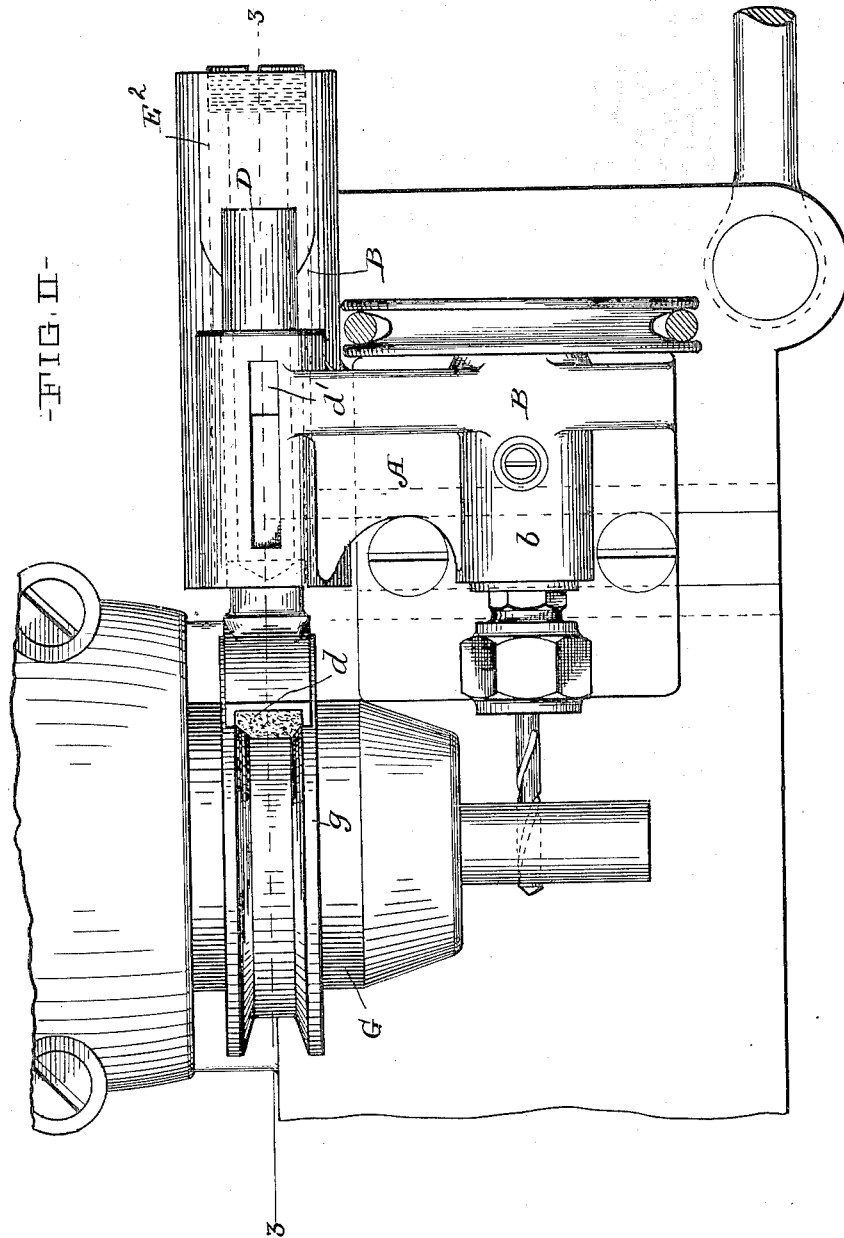

-FIG. II-

Witnesses,

*J. C. Turner*  
*A. C. Merkel*

Inventor,

By *J. P. Brophy*  
*J. D. Fay* Atty.

No. 649,904.

Patented May 22, 1900.

J. P. BROPHY.  
AUTOMATIC LATHE ATTACHMENT.

(No Model.)

(Application filed July 17, 1899.)

3 Sheets—Sheet 3.

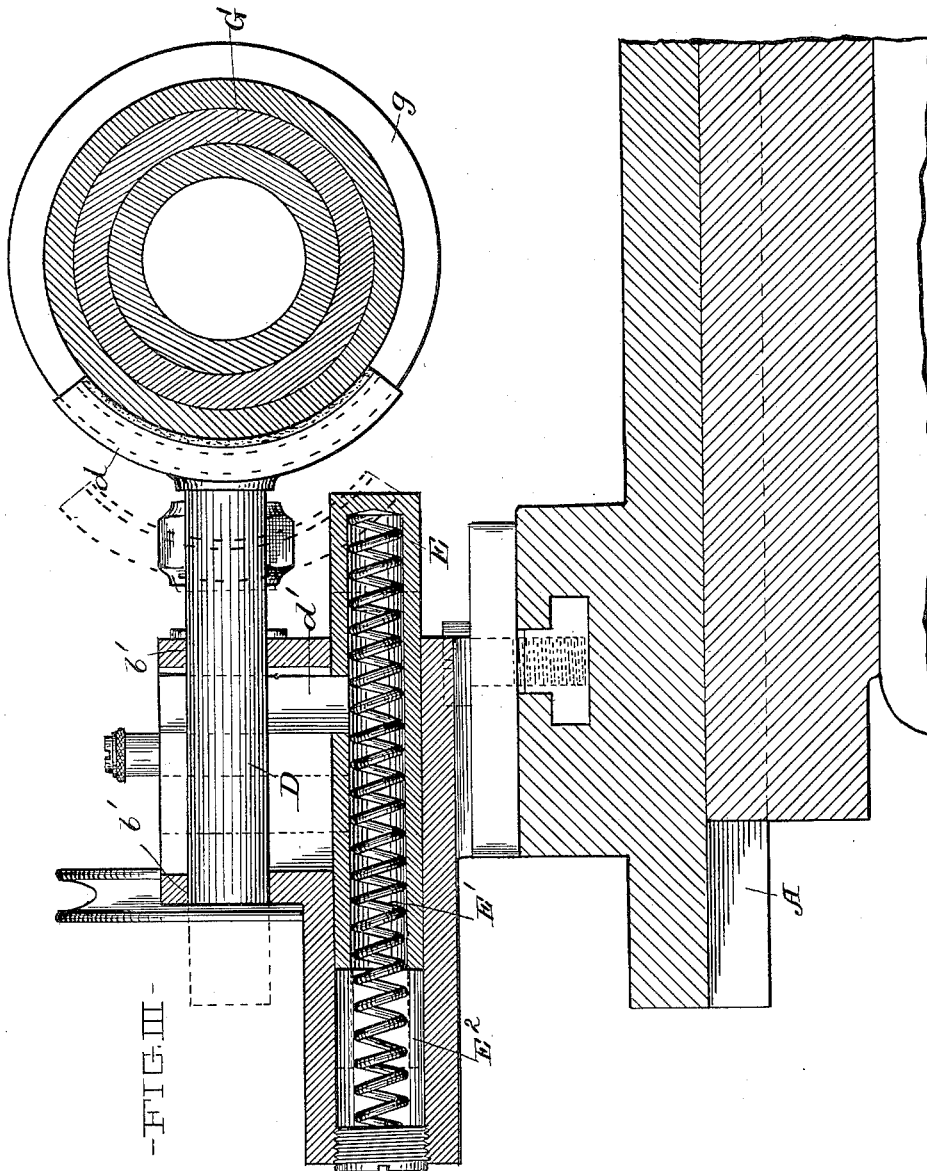

-FIG. III-

Witnesses,  
*J. C. Turner*  
*W. C. Emerkel*

Inventor,  
*J. P. Brophy*  
By *J. De Fay* Atty.

# UNITED STATES PATENT OFFICE.

JOHN P. BROPHY, OF CLEVELAND, OHIO, ASSIGNOR TO THE CLEVELAND MACHINE SCREW COMPANY, OF SAME PLACE.

## AUTOMATIC LATHE ATTACHMENT.

SPECIFICATION forming part of Letters Patent No. 649,904, dated May 22, 1900.

Application filed July 17, 1899. Serial No. 724,091. (No model.)

*To all whom it may concern:*

Be it known that I, JOHN P. BROPHY, a citizen of the United States, and a resident of Cleveland, county of Cuyahoga, and State of Ohio, have invented a new and useful Improvement in Automatic Lathe Attachments, of which the following is a specification, the principle of the invention being herein explained and the best mode in which I have contemplated applying that principle so as to distinguish it from other inventions.

My invention relates to attachments for automatic lathes for performing a special operation upon the work in connection with other operations to be performed by the tools in the turret, and particularly to that operation called "side drilling," in which a cylindrical or other blank is required to be drilled in a direction transverse to its axis of rotation, said invention consisting of means hereinafter fully described.

The annexed drawings and the following description set forth in detail certain mechanism embodying the invention, such disclosed means constituting but one of various mechanical forms in which the principle of the invention may be used.

In said annexed drawings, Figure I represents an end view of the head-stock of an automatic lathe, showing an end elevation of a cross-slide and my improved drilling device as applied thereto. Fig. II represents a top plan of same, showing only the end of the head-stock with a blank secured therein; and Fig. III represents a vertical section taken upon line 3 3, Fig. II.

Upon a cross-slide A is secured a housing B, in the upper part of which is formed a bearing b, Fig. I, in which is mounted a spindle C, on one end of which is provided a suitable chuck for securing a drill and upon the opposite end of which is secured a sheave, as shown in Fig. II. Through a bearing b', formed upon the housing, Figs. II and III, extends a longitudinally-movable rod D, upon the end of which is formed or secured a segmental brake member or shoe d of trapezoidal cross-section, whose friction-surface is made of leather, rubber, or other suitable material. A pin or key d' extends through said rod D and is secured to the top of a bar-

rel E, in which is located a spring E', said barrel sliding freely in a bore E<sup>2</sup> formed in the housing, as shown in Fig. III. One end of said spring abuts the end of said barrel and extends through the opposite end thereof, abutting the closed end of said bore, as shown. The direction of travel of the rod and barrel is at right angles to the axis of the head-stock G of the lathe, and the spring actuates the brake-shoe d toward said axis, the key d' limiting the movement in the direction by engaging the housing, in which is formed part of the bearing for rod D, as may be understood from Fig. III. In the line of travel of the brake-shoe d and secured to or formed upon the rotating head-stock G is a second brake member g, consisting of a wheel provided with a groove having a trapezoidal cross-section similar to, but of less area, than that of said brake-shoe.

The device operates as follows: The drill-chuck and drill are rapidly rotated by a belt running upon the sheave, and suitable mechanism is provided for reciprocating the cross-slide, the advance and return being imparted at the proper time. The length of the stroke of the slide is made such that the brake members will not be in engagement at the end of the return stroke, as shown in dotted lines, Fig. III. The blank article to be cross-drilled being rapidly rotated for the operation of other tools which are required to perform their respective functions and the head-stock-driving means having been automatically disconnected the cross-slide is advanced toward the blank for the purpose of cross-drilling. Before the drill reaches its point of entrance, however, the two brake members come into operative engagement, Fig. I, and on the continued advance effect the discontinuance of the rotation of the head-stock. After such discontinuance the slide continues to advance, causing the brake-shoes to yield, respectively, to the cross-slide, and the rod D is pushed back against the action of the spring E', the barrel E entering the bore E<sup>2</sup>, and during the time that the drill is entering the blank, as shown in Fig. II, the latter is held firmly and continuously against rotation, thus permitting the drilling operation to be perfectly performed. On the return stroke of the

slide the drill is withdrawn and after such withdrawal and the continued retraction the brake members are disengaged, permitting the head-stock-rotating means to be again thrown  
 5 into gear and any further desired operation permitted without any frictional resistance on behalf of the brake mechanism.

Other modes of applying the principle of my invention may be employed instead of the  
 10 one explained, change being made as regards the mechanism herein disclosed, provided the means covered by any one of the following claims be employed.

I therefore particularly point out and distinctly claim as my invention—  
 15

1. In an automatic lathe, the combination of means for rotating a blank, a tool for operating upon such blank, means for advancing said tool toward the latter, said rotating and  
 20 advancing means each provided with a brake member, such members adapted to cooperate to brake the rotation of said blank on the advance of the tool, substantially as set forth.

2. In an automatic lathe, the combination  
 25 of means for holding and rotating a blank, a drill mounted upon a cross-slide, means for reciprocating said cross-slide whereby said drill may be caused to enter the blank in a direction transverse to the axis of rotation

of the latter and a brake member mounted  
 upon said slide and cooperating with a brake  
 member connected with the blank-holding  
 means to brake the rotation of the blank on  
 the advance of the slide toward the latter,  
 substantially as set forth. 35

3. In an automatic lathe, the combination of a rotatable blank-holder, a drill mounted upon a cross-slide, means for reciprocating said slide, a brake member secured to said blank-holder, and a yielding brake member  
 40 mounted upon said slide and adapted to cooperate with said first-named brake member, substantially as set forth.

4. In an automatic lathe, the combination of a rotatable blank-holder, a drill mounted  
 upon a cross-slide, means for advancing said  
 slide toward said holder, a brake member rotatable with the latter, and a spring-actuated  
 brake member mounted upon said cross-slide  
 and adapted to engage said first-named brake  
 50 member on the advance of said slide, substantially as set forth.

Signed by me this 5th day of July, 1899.

J. P. BROPHY.

Attest:

D. T. DAVIES,  
 A. E. MERKEL.